

SCHLAGEL MFG

4154 Buttermilk Road
Torrington, WY 82240

Phone: 307-532-4451

Fax: 307-532-8994

Website: www.schlagel.net

E-mail: sales@schlagel.net

SCHLAGEL

Plug Locks & Valve Locks
For Gated Pipe
& Dam Supports

Toll Free 1-888-889-1504

Plug Locks

The EASY WAY to secure irrigation pipe plugs...no more driving fence posts to hold plugs.

The Plug Lock also is an easy tool to pull pipe apart!

Available in 6", 8", 10" & 12" sizes

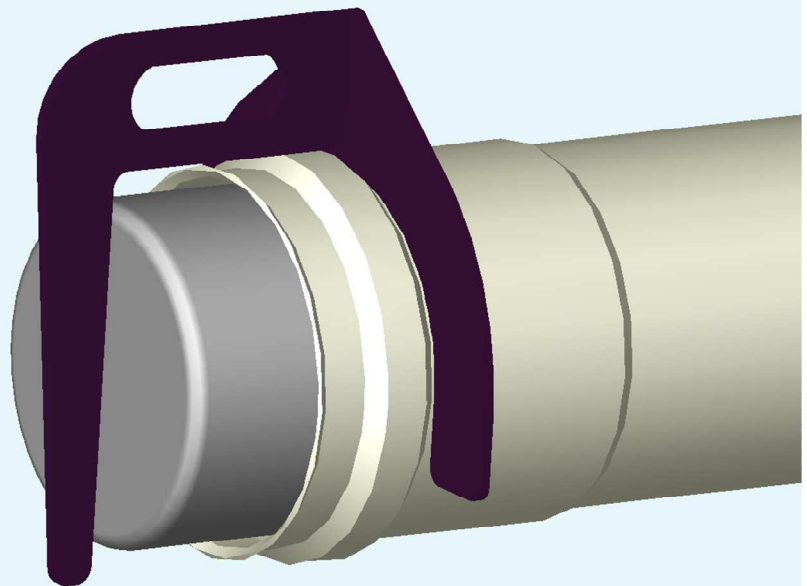

Valve Locks

The EASY WAY to secure irrigation valves.

Available in 8" & 10" sizes

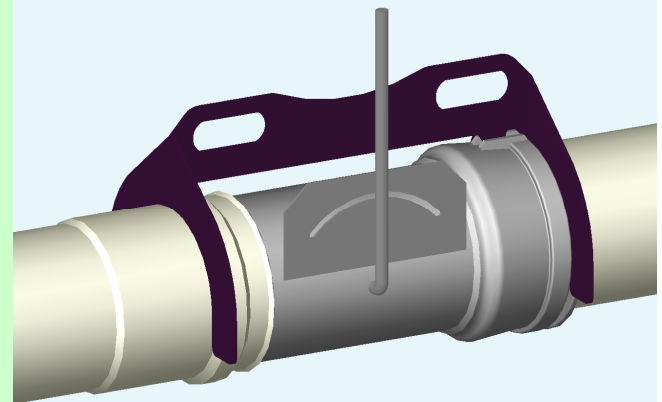

Metal Dam Supports

Item # Dam-133 (A=12" B=33.5" C=15")

Item # Dam-139 (A=12.25" B=39.25" C=19")

Or give us dimensions and we can build what you need...

