

BALE FORKS



BALE FORKS

GREATER VISIBILITY & CONTROL

Handle two large, square bales at once with our BF-400 series bale forks!

Our bale forks are designed to work without a bucket, providing you with greater visibility for positioning bales, more control for tighter stacking, and an overall lighter weight for less wear on pins.

For deep penetration and stability, each bale fork has two rows of long bale spears. Options are available for either four or five spears on the bottom row in configurations of all long spears, all short spears, or a combination of both. You can even have two additional spears installed in the center cross member, if needed.

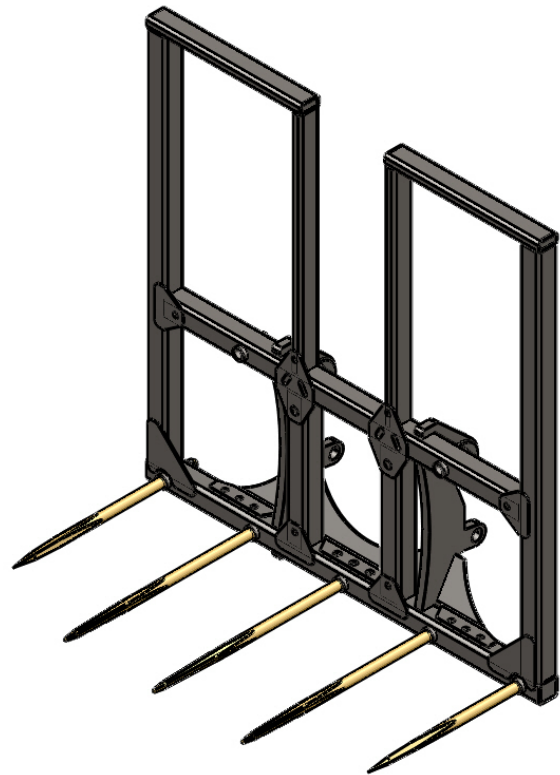



Mounting and quick-tach kits
are available for most loaders,
or we can engineer mounts to fit.
Just ask!



 **SCHLAGEL**

Our products are simple, yet stalwart, and they're built and tested to ensure they'll be in it for the long haul. Visit our website to locate a trusted Schlagel dealer near you. Have questions? Just give us a call!

www.schlagel.net

307.532.4451

